

TEX

design Raw Edges

colours

sizes

technical features

packing

MU
TIN
A[®]

TEX

sizes

colours

technical features

packing

La collezione Tex viene realizzata in gres porcellanato con assorbimento < 0,5% ed è quindi adatta ad un utilizzo sia da pavimento che da rivestimento, in interni ed esterni. Presenta cinque diverse texture ottenute imprimendo sulla superficie dei disegni a rilievo. Viene smaltata attraverso un processo automatico che consente di realizzare per ciascun colore tre toni in ugual percentuale prima di indirizzarla verso un ciclo di cottura in cui si raggiungono temperature fino a 1.200°. Il prodotto così ottenuto presenta una superficie assolutamente opaca, leggermente strutturata ma morbidissima al tatto, facile da pulire perché pensata all'utilizzo sia a rivestimento che a pavimento. Ciascun rombo in formato 11,5x20 cm ed avente spessore 10 mm, pur presentando piccole irregolarità dimensionali volute dai designer, si posa agevolmente con l'impiego di distanziatori da 2 mm e stuccando le fughe in tono su tono.

Tex collection body is realized in porcelain stoneware < 0,5% absorption. This production makes it suitable either for floors and walls, indoor and outdoor. It presents five different textures, obtained by pressing on the surface relief-patterns. The tile is then glazed using an automatic process, which enables the realization in the same percentage of three different shades for each color. The tile finally undergoes a baking process which reaches temperatures up to 1.200°. The obtained product has an absolutely matt surface, slightly structured but very soft to the touch, which is also very easy to clean since thought both for wall and floor covering. Each rhombus in size 11,5x20 cm and with thickness 10 mm, is easily fixed using 2 mm spacers and using a matching grout, even if they have some small size irregularities made on purpose by the designers.

TEX / sizes

Modello depositato n° 002193797-0001/0014 - data di deposito: 28/02/2013 - Registered design n° 002193797-0001/0014 - date of registration: 28/02/2013

design Raw Edges 2012-2017

production industrial

material gres porcellanato smaltato – glazed porcelain stoneware

thickness 10

*misure nominali - nominal sizes



11,5-20
* 4 1/2" · 8"

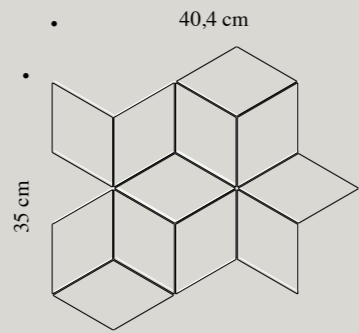

runner 35-40,4
* 13 25/32" · 15 29/32"

complementary pieces

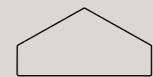

10,5-20
* 4 1/8" · 8"
battiscopa - skirting

TEX / colours



cream



brown



white

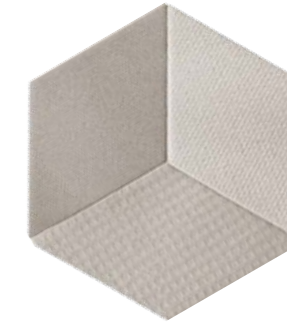

grey



black

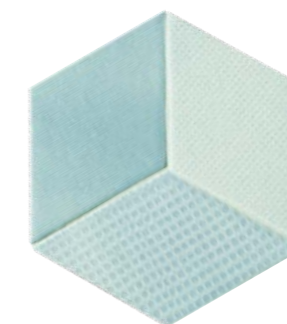

blue

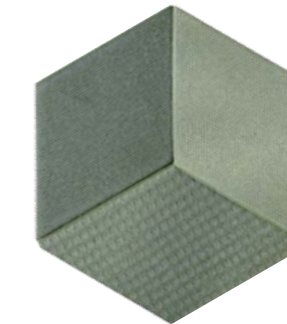

olive



yellow

TEX / runner

Il Runner è un elemento composto da 12 rombi di vari colori già posati su rete per la realizzazione facilitata di svariate decorazioni.

The Runner is an element composed by 12 rhombus of different colours already set on mesh, so to make the realization of several decors easier.

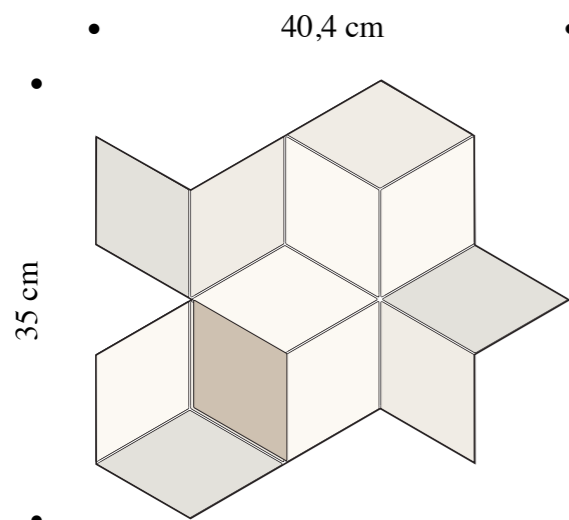

Ogni Runner è composto da 8 moduli diversi, non vendibili separatamente ed inclusi in un unico imballo, che permettono di creare molteplici combinazioni.

Each Runner is composed by 8 different patterns, not singularly sold and already included in one single package, which enable the realization of many combinations.

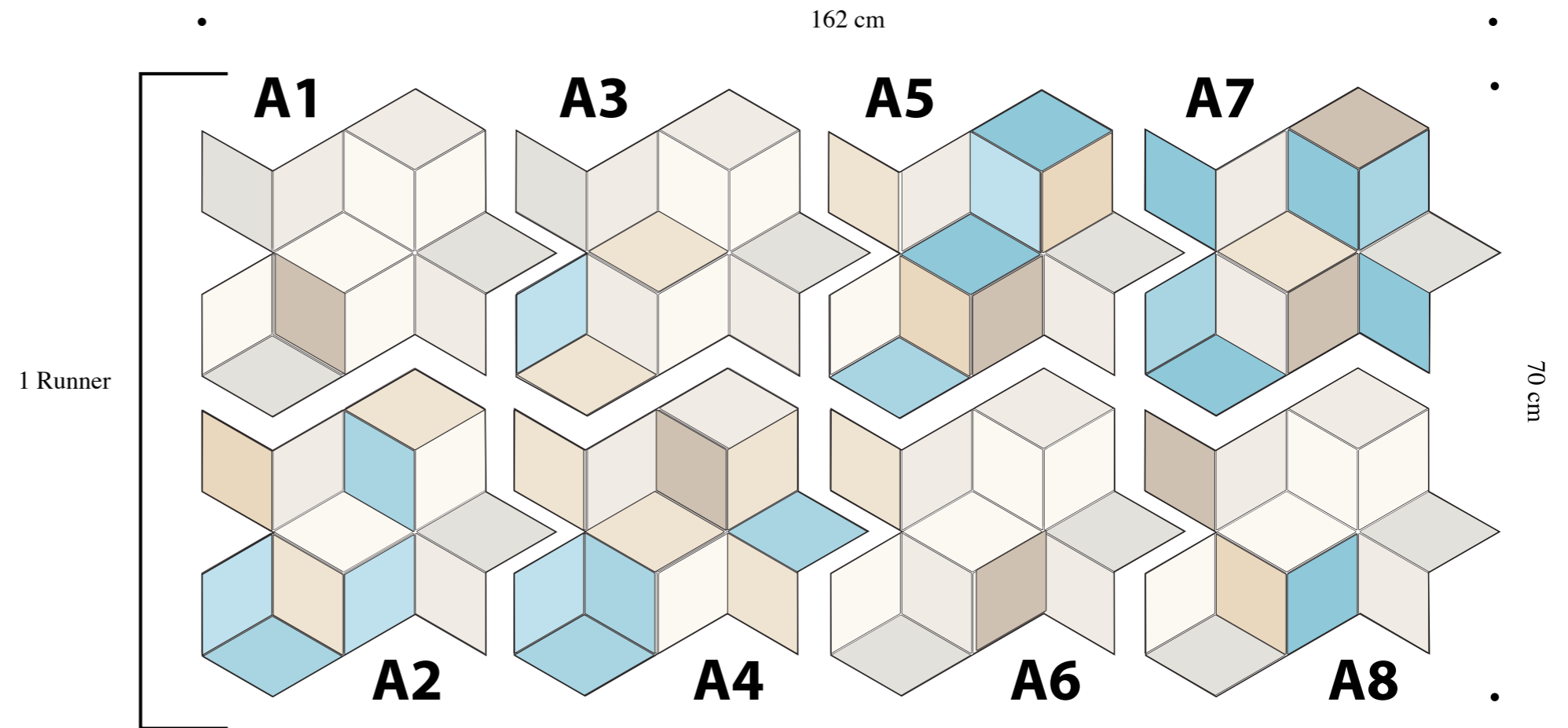

1 Runner = 8 moduli = 1,12 mq - 1 Runner = 8 patterns = 1,12 sqm

Esistono 10 Runner: ognuno abbinato a ciascun colore della collezione, per il colore white ce ne sono 3.

There are 10 Runners, each of which combined to every colour of the collection. For the white one there are 3 of them.

TEX / runner colours

10 Runner, ognuno composto da 8 moduli diversi, in abbinamento ai colori della collezione.

10 Runners, each of which is composed by 8 different patterns, matching with the colours of the collection.

RUNNER 1 WHITE
(white + yellow & cream)

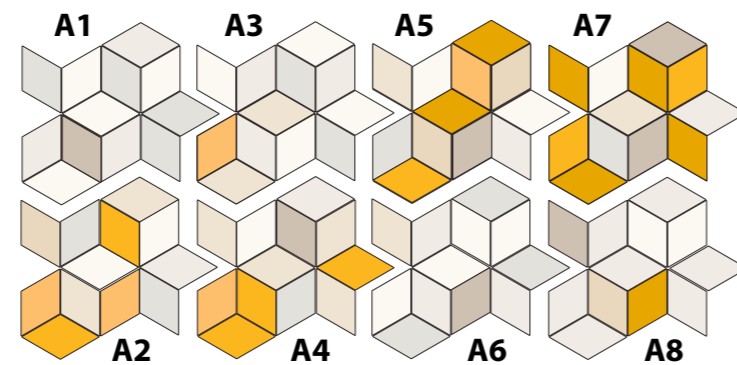

runner 4 CREAM
(cream + brown & white)

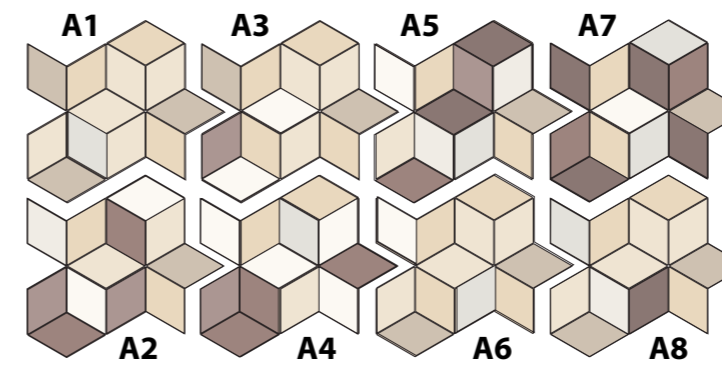

runner 7 BLACK
(black + grey & white)

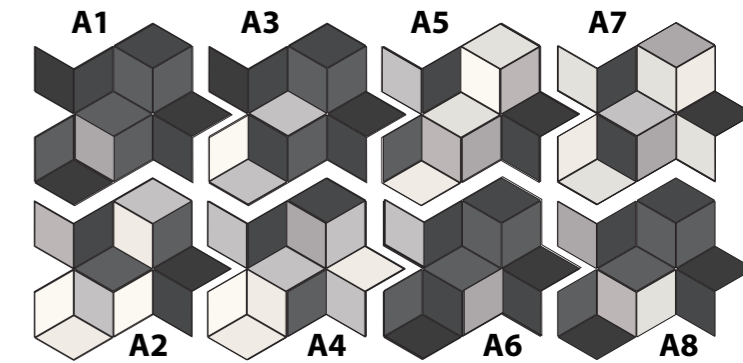

runner 8 OLIVE
(olive + cream & white)

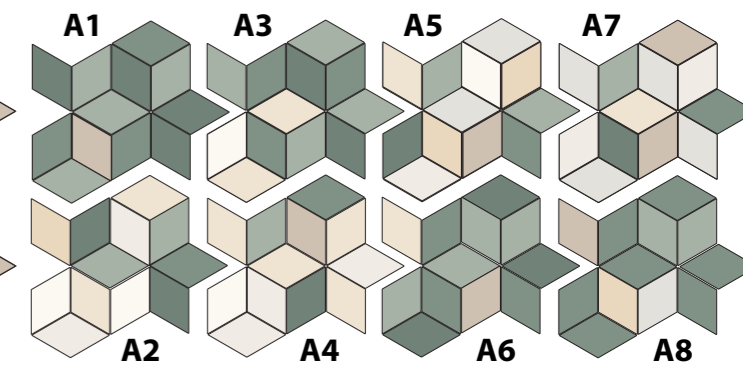

runner 2 WHITE
(white + olive & cream)

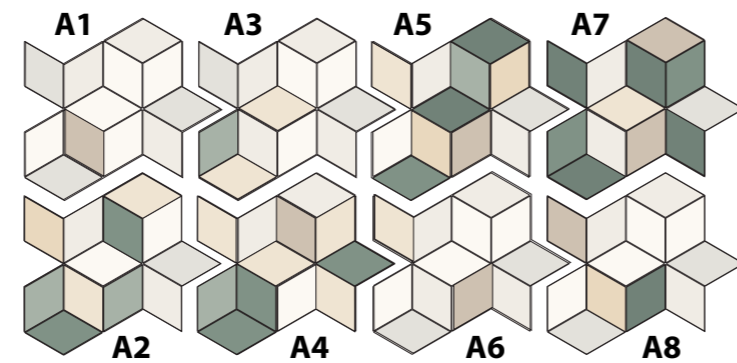

runner 5 BROWN
(brown + cream & white)

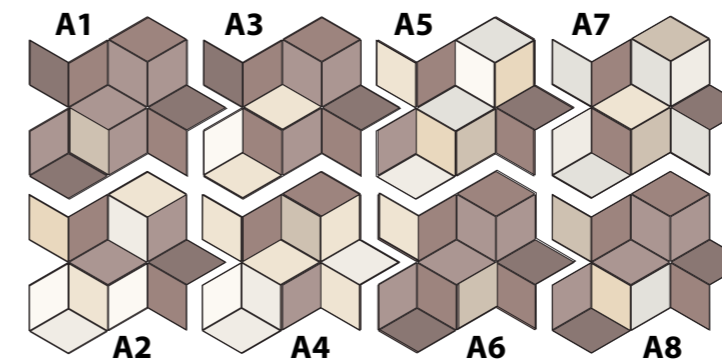

runner 9 BLUE
(blue + cream & white)

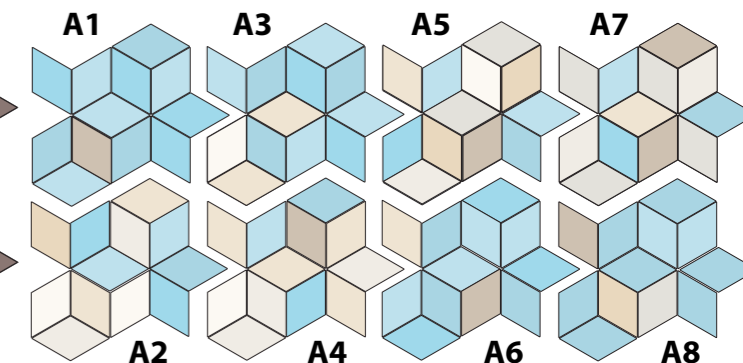

runner 3 WHITE
(white + blue & cream)

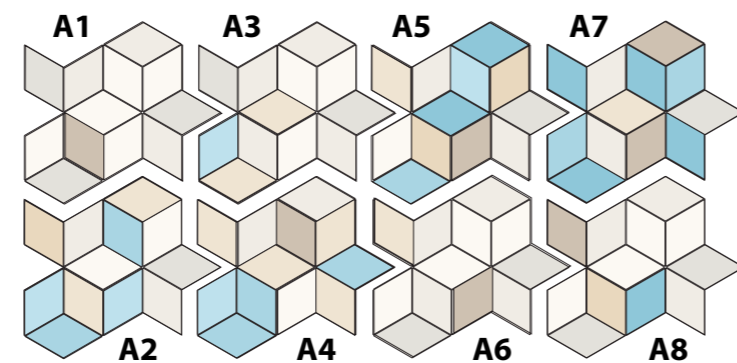

runner 6 GREY
(grey + cream & white)

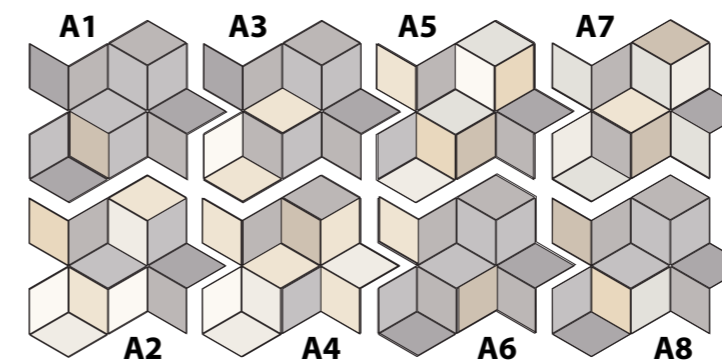

runner 10 YELLOW
(yellow + cream & white)

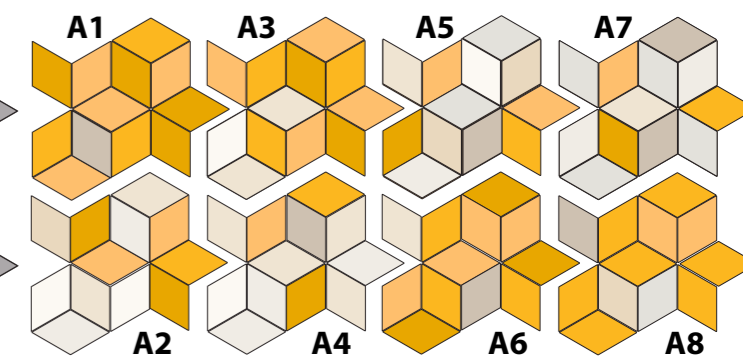

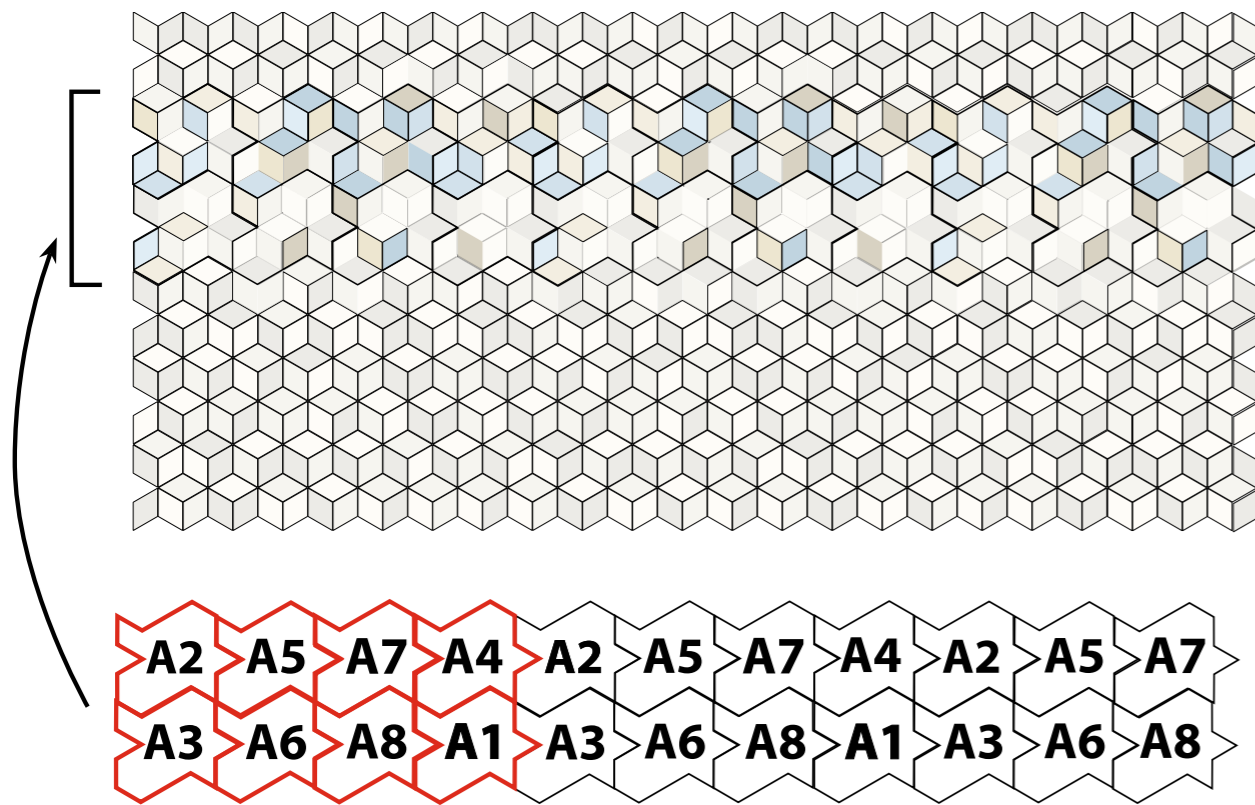

Esempio di posa 1 - Laying scheme 1
 Composizione singola - Single composition

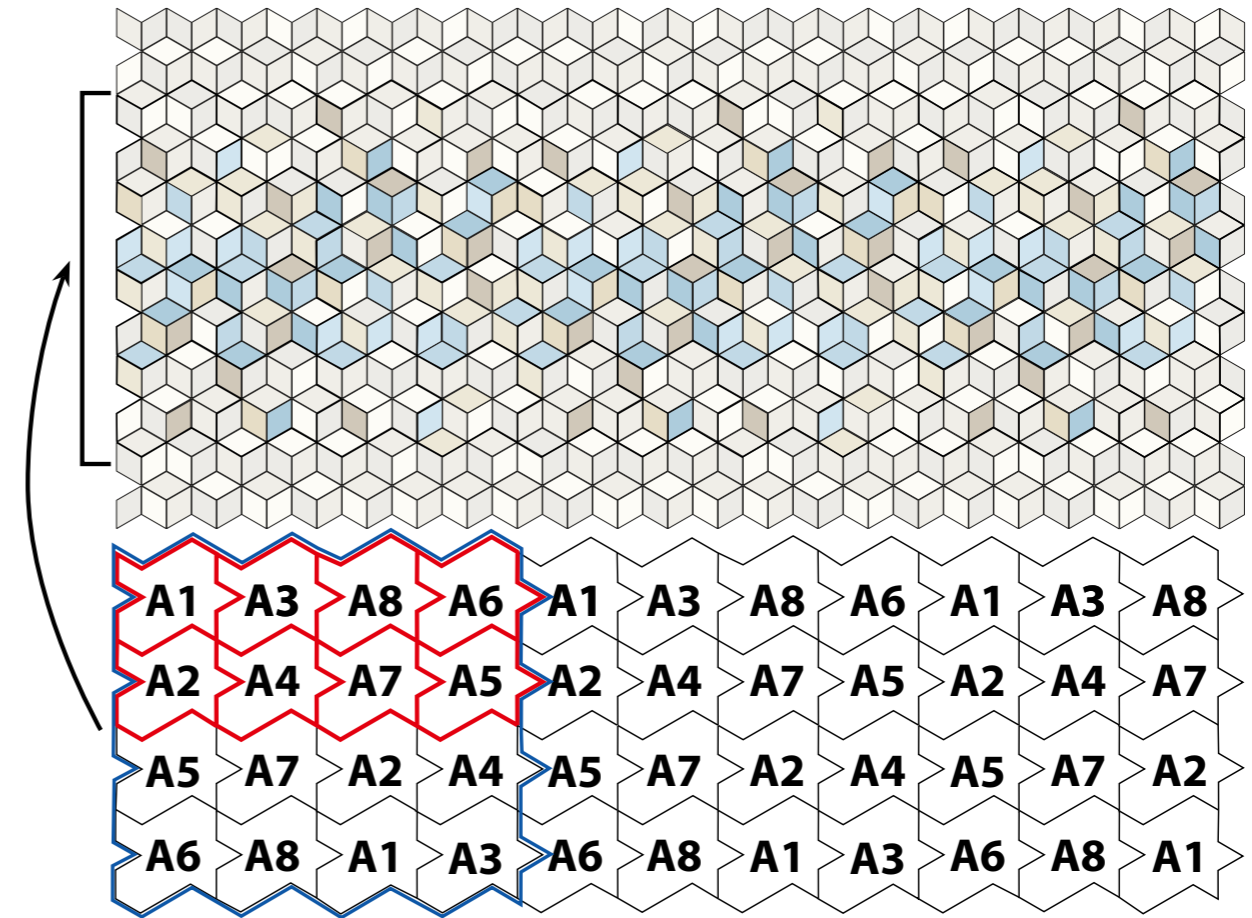

Esempio di posa 2 - Laying scheme 2
 Composizione doppia - Double composition

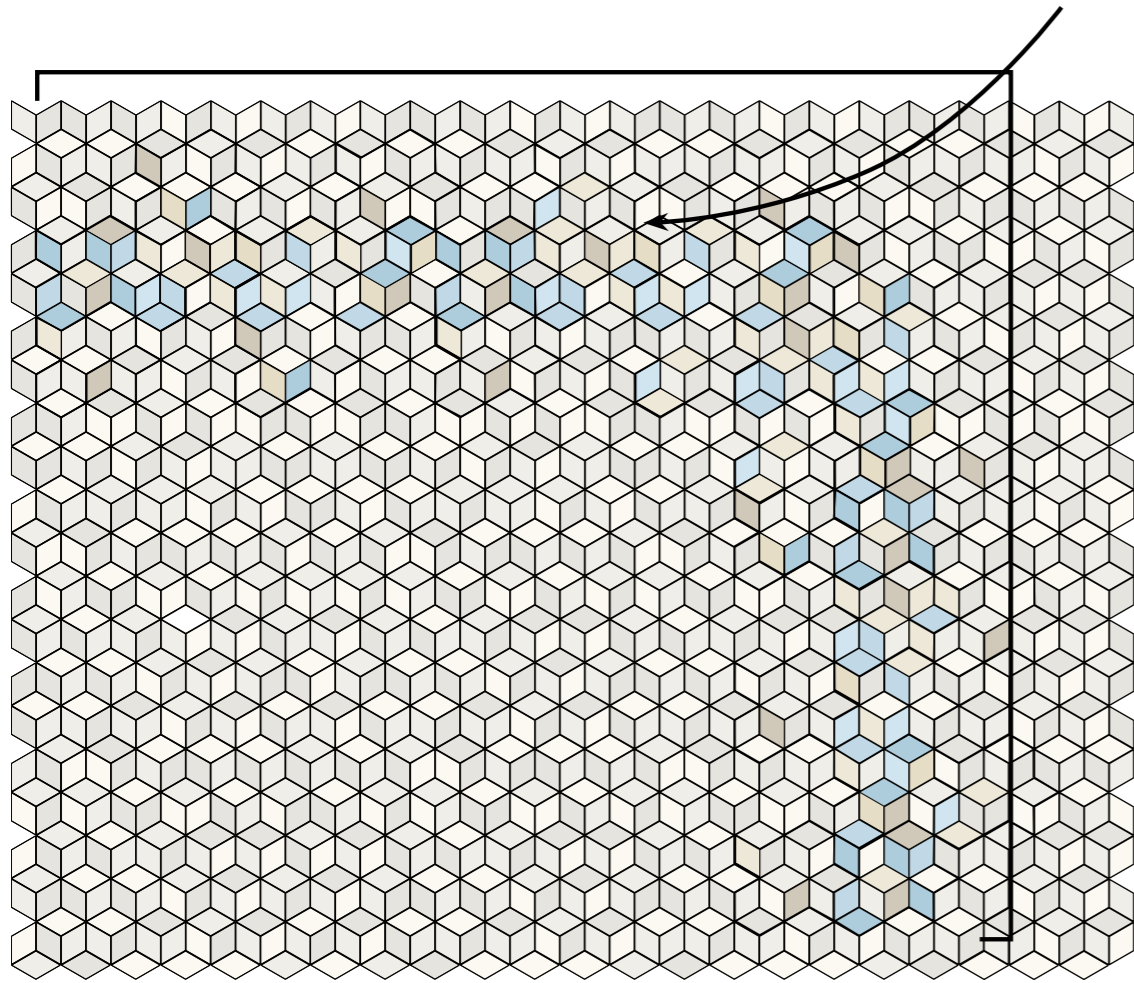
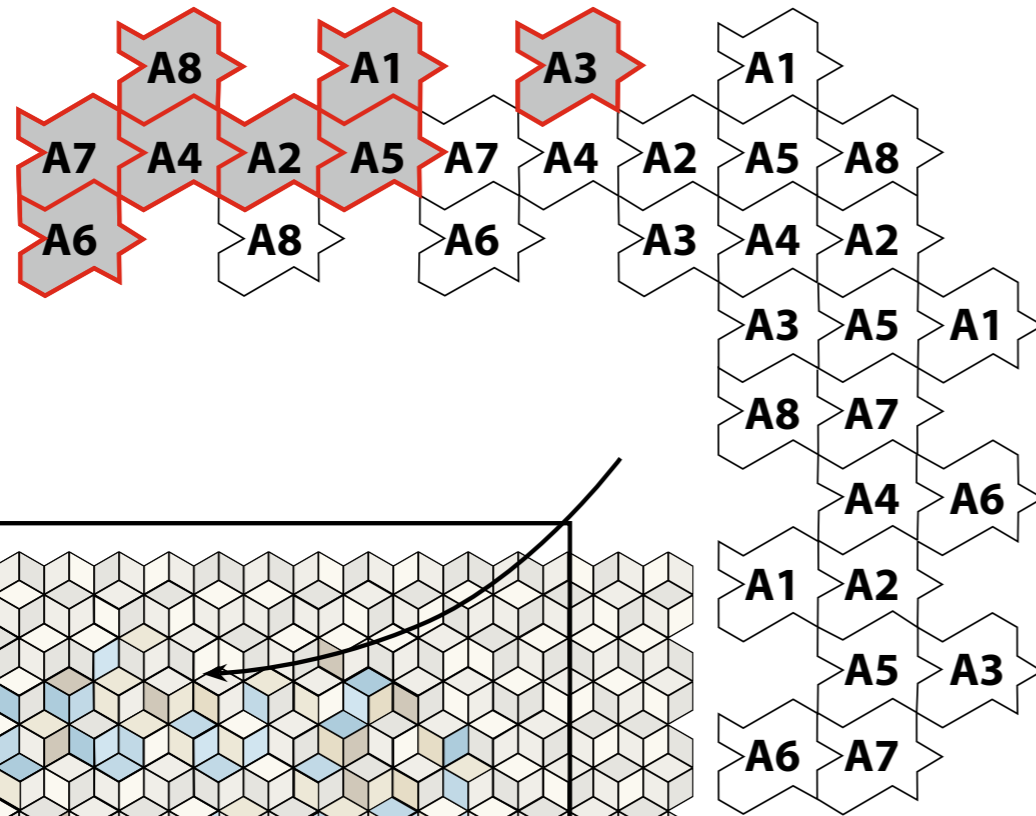

Esempio di posa 3 - Laying scheme 3

Composizione libera - Free composition

TEX / technical features

UNI EN14411:2012 App. GL. (Bla Group)

norma standard	caratteristiche features	valore prescritto value required	TEX
ISO 10545/3	assorbimento d'acqua water absorption	<0,5%	<0,5%
ASTM C373		<0,5%	<0,5%
EN 101	durezza superficiale (scala mohs) surface hardness (scala mohs)	≥ 5	6
ISO 10545/9	resistenza agli sbalzi termici resistance to thermal shock	nessuna alterazione visibile no visible alteration	resiste resistant
ISO 10545/12	resistenza al gelo frost resistance	nessuna alterazione visibile no visible alteration	resiste resistant
ASTM C1026		unaffected	unaffected
ISO 10545/13	resistenza agli attacchi chimici resistance to chemical attacks	nessuna alterazione visibile no visible alteration	resiste GA - GLA - GHA resistant GA - GLA - GHA
ASTM C650			unaffected
ISO 10545/14	resistenza alle macchie stains resistance	≥ classe 3 min	5
ISO 10545/4	sforzo di rottura (N) breaking strength (N)	Sp≥ 7,5 min 1300	resiste resistant
DIN 51130 - 04		valori medi 6° ÷ 10° 10° ÷ 19° 19° ÷ 27° 27° ÷ 35° > 35°	R9 R10 R11 R12 R13 R10
DCOF		> 0,42	0,58
BCRA	scivolosità anti-slip	> 0,40	leather on dry surface 0,53 rub on wet surface 0,49
LEED CERTIFICATION 4.1			24% recycled material

TEX / packing

formato size	pz-mq pcs-sqm	pz-scat. pcs-box	mq-scat. sqm-box	scat.-pal. box-pal.	kg-scat. kg-box	kg-pal. kg-pal.	mq-pal sqms-pal
11,5-20	86,96	44	0,51	88	10,45	920	44,88
runner 50-46	0,91 set	1 set*	1,12	36	22,55	812	40,32
battiscopa 10,5-20	-	10	2,0 ml	-	3,25	-	-

*1 set = 8 pcs